

Vintage LED Cafe Lights, 48ft., 24 Bulbs



Specifications

Length of fixture: 48' **Nominal wattage:** 24
Voltage: 120 **Hertz:** 60 **Color Temperature:** 2200K
Max linkable: 750ft **Lifetime:** 50,000 hours
Warranty: Limited-lifetime warranty

Design Features

- Lifetime LED – JascoPro™ Series café lights are designed with premium long-life, cool to the touch and energy-efficient LEDs, which means no bulbs to replace
- 24 commercial grade, impact resistant acrylic Edison-style bulbs won't break if dropped, stepped on or blown around in the wind
- Weatherproof – Heavy duty 18/3 SJTW cord withstands up to 221°F outdoor temperature for year-around usage. Designed for permanent installation and to withstand year-round exposure to the elements
- Flexible mounting options – Mount on a flat surface or hang from above (mounting hardware not included)
- Linkable up to 750 feet – End-to-end connections; link multiple sets to achieve the perfect length for any installation
- UL listed, FCC certified

GUARANTEE
10-year
 NEVER REPLACE
 A BULB AGAIN

WEATHER PROOF
 Commercial grade and UL-rated
 for permanent outdoor installation

IMPACT RESISTANT
 Durable acrylic bulbs won't
 break if dropped, stepped on,
 or in severe weather.

120V | LED | 1WATT PER LIGHT | 2200K WARM WHITE

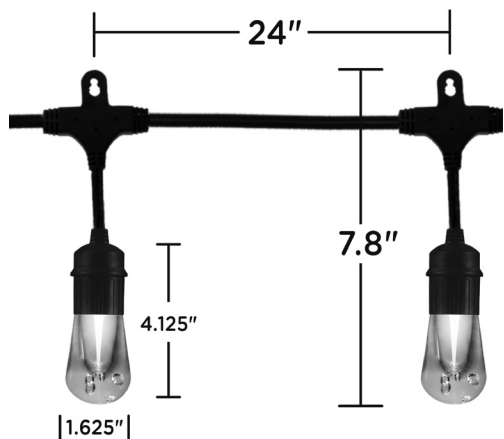

Additional Installation Information

- When installing Café Lights outside, a Ground Fault Circuit Interrupter (GFCI) receptacle should be used. Before installing, plug the Café Lights into the GFCI receptacle to ensure all lights work properly.
- Only mount Café Lights to a solid support structure such as joists, beams, studs or other solid mounting surfaces.
- Guide wires in compliance with local electrical and building codes may also be used to support Café Lights.
- When finished mounting, place the female receptacle cover firmly over the unused outlet and plug the male plug into the GFCI receptacle.

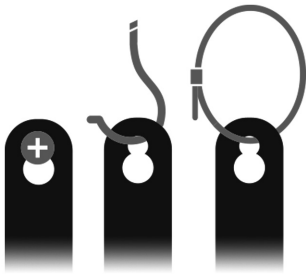

EASY INSTALLATION AND FLEXIBLE MOUNTING OPTIONS

Mount on a flat surface or hang from above.
(Mounting hardware not included)

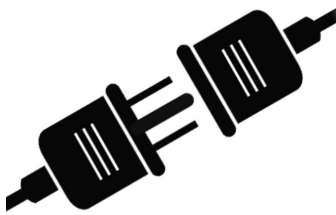

CONNECT MULTIPLE STRINGS

Heavy-duty, grounded cord plugs into any standard outlet. Link multiple Café Lights up to 750 feet.

Certifications & Compliances



Compliances, specifications and availability are subject to change without notice

Distributed by Jasco Products Company LLC
10 E. Memorial Rd., Oklahoma City, OK

Questions? Contact our U.S.-based Consumer Care at
1-800-654-8483 between 7AM-8PM, M-F, Central Time.

©Jasco 2022