

JascoPro™ Series Wi-Fi LED Landscape Lights, 50ft., 6 Pucks



**NEVER REPLACE
A BULB AGAIN**



MULTIPLE MOUNTING OPTIONS

Mount lights facing up, down or stake into the ground



WEATHER PROOF

Commercial grade and UL-rated for permanent outdoor installation

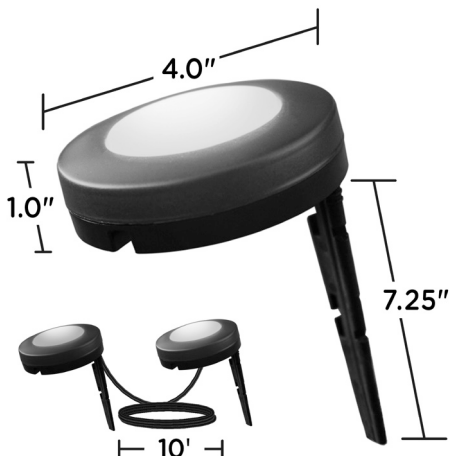

Specifications

Length of fixture: 50' **Lumens:** 150 per puck

Voltage: 120 **Hertz:** 60 **CRI:** 83 **Nominal wattage:** 26

CCT: 2200K - 6000K **Signal Frequency:** 2.4GHz

Operating Temperature Range: -4 - 122° F (-20 - 50° C)

Lifetime: 50,000 hours **Warranty:** 3-year limited warranty

Design Features

- 6 commercial grade, oil-rubbed bronze metal puck light fixtures illuminate up to a 50-foot area
- Flexible spacing - includes 22ft. lead wire and 10ft. spacing between lights. Burial grade cable allows hiding excess cable under mulch or soil
- Weatherproof – Commercial grade and UL-rated for permanent outdoor installations
- Free JascoPro Series App – no hub required
- Wi-Fi or Bluetooth setup and control
- Manual control button for manual operation
- Mobile or voice control – works with Alexa and Hey Google
- Selectable color modes – Choose from 56 single colors; holidays & events presets, 2- and 3-color combinations to create your own
- Dimmable – Full-range dimming
- Selectable white - 2200K - 6000K
- Schedules and timers
- Flexible mounting options – Mount lights facing up, down or stake into the ground. Stake as path, spotlight or accent light. Stakes included
- UL listed, FCC certified

Additional Installation Information

- Landscape lights feature 18 AWG UV stabilized direct burial-grade cable. This allows you to conceal excess cable by directly burying it in the soil or covering it with garden bedding.
- When mounting lights up, use the keyholes on the back or ear-tabs on the side — screws not included.
- Use #6 pan head screws (not included) to mount each puck to a solid support structure such as joists, beams, studs and more.

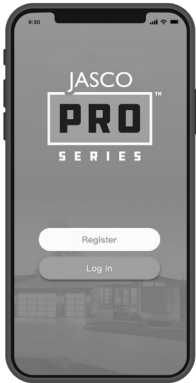

EASY APP CONTROL

Download the free JascoPro Series app to control your devices from anywhere.

MULTIPLE MOUNTING OPTIONS FOR UP OR DOWN LIGHTING

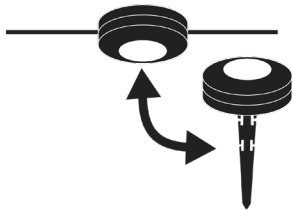

Mount lights facing up, down or stake into the ground



Stake as path or spotlights



Burial-grade cable

FLEXIBLE SPACING UP TO 10 FEET

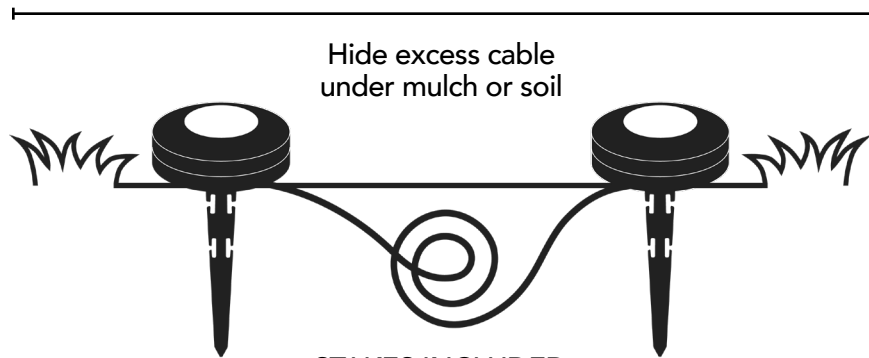

STAKES INCLUDED

Certifications & Compliances



Compliances, specifications and availability are subject to change without notice

Distributed by Jasco Products Company LLC
10 E. Memorial Rd., Oklahoma City, OK

Questions? Contact our U.S.-based Consumer Care at 1-800-654-8483 between 7AM-8PM, M-F, Central Time.

©Jasco 2022